



MONOTONE
SERIES

800x2400mm

15mm Thickness



ABOUT COMPANY

Motto is one of the most dynamic & productive brands of the modern ceramic world that is brought to life by a visionary person Mr. Mahendra Patel. Over the years the company has developed manifold.

Since 2004 - the inception year, to today we have expanded our reach to national & international arenas with a capillary presence in more than 70+ countries with 2500 satisfied customers.

Finest skills clubbed with state of the art technology have helped us to carve a niche, which is stamped by authorities as we are ISO 9001 : 2018 Certified. Overall the company has marked its position as the leading Manufacturer, Exporter and Supplier of the exquisite Ceramic Porcelain Tiles for Wall & Floor.

MONOTONE
/ COLLECTION - 2024

MONOTONE SERIES

The Monotone Series is a beautiful selection of solid-colored expansive slabs with a truly functional matt finish. Designed for contemporary interiors, the colors of the series deliver a delicate balance - balancing opulence without overwhelming the senses. The series also delivers exceptional strength paired with a size most ideal for elaborate details.

Get ready to experience modern luxury and exceptional functionality.

THE LARGEST SIZE FOR ARCHITECTURAL ASPECTS

The slabs of the series offer everything but nothing ordinary. The full body is expertly engineered with a thickness of 15mm and an 800 x 2400 mm size to offer superior solutions to modern architectural needs.

Addressing modern demands, these slabs offer standalone applications and perform well in demanding applications.

FULL BODY
SERIES

15mm
Thickness

Design your space
larger than life with
an exceptionally
bigger size.

800x
2400mm



**BIGGER
SIZE
BIGGER
STYLE**

**EVOKE
RICH
SHADES**

- 01 **JUNIPER**
800x2400mm
- 02 **PEACH**
800x2400mm

TRUE COLORS FOR TELLING A LUXURIOUS STORY

Unleash endless possibilities with rich colors that bring consistent and pure energy to your space. The selection of colors is thoughtfully curated to reflect your unique style and personality.

The solid colors infuse your space with zeal and coziness, transforming your living environment into an oasis of harmony.

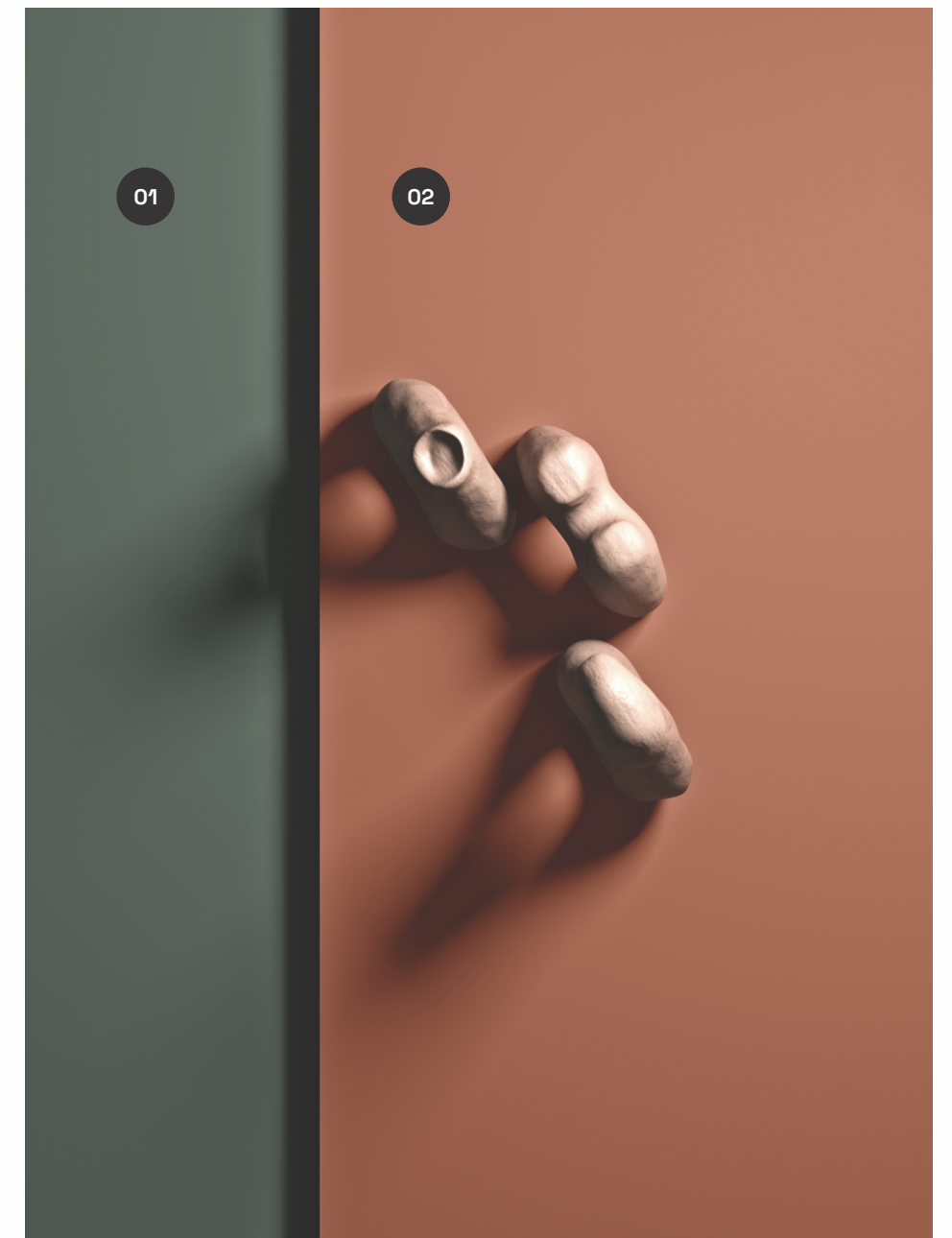

Italian Technology |  FLEXIBLE BODY

11

SOLID
MODERN COLOR
SHADES

PERSONALIZE
IT YOUR WAY



MONOTONE - CLAY
800x2400mm / 15mm

ENDLESS
POTENTIAL
ENDLESS
DESIRE



The 15mm robust thickness of the series opens extensive possibilities for crafting functional and aesthetic edge profiles for your table tops, counter tops, and more.

The series size, in addition, facilitates multiple joint possibilities to craft neat counter tops, table tops, and more.

EDGE PROFILES



Squared
ridge at 45°



Rounded
ridge at 45°



Straight
squared ridge



Rounded
straight ridge



Double straight
squared ridge



Double straight
rounded ridge

JOINT POSSIBILITIES



Birds beak



45° corner



Soft corner

ENDLESS IMAGINATION ENDLESS POSSIBILITIES

MONOTONE
/ COLLECTION - 2024



COUNTER TOPS
Monotone Clay



INTERIOR FLOOR
Floor : Monotone Dust



VANITY TOPS
Monotone Pastel



READING TABLE
Monotone Peach



BLEACHER STAIRS
Monotone Dust



OFFICE TABLE
Monotone Oxford



FURNITURE
Monotone Olive



DINING TABLE
Monotone Denil

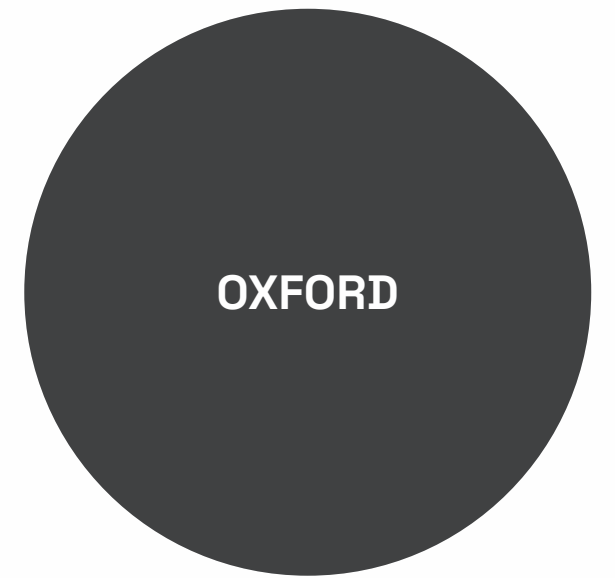
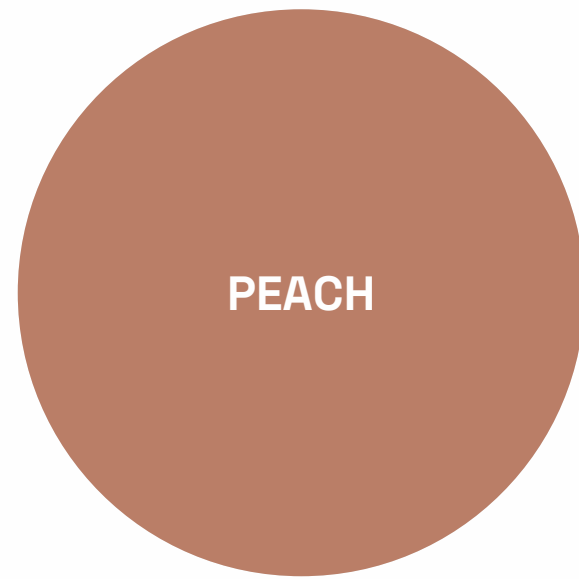
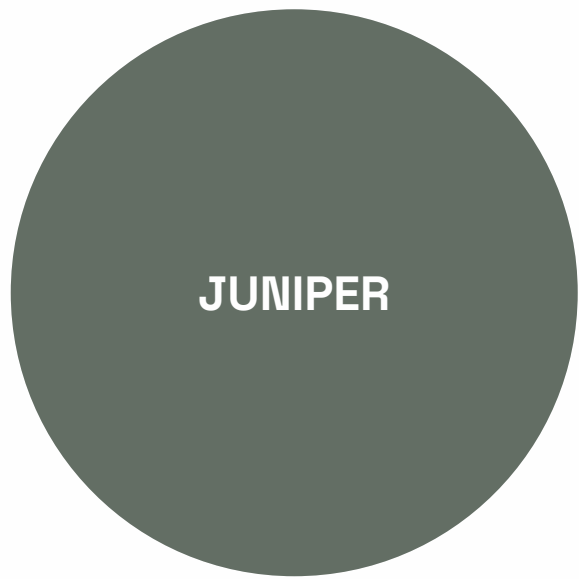

TABLE OF CONTENT
/ PAGE INDEX





INSPIRED
FROM THE
ESSENCE
OF TRUE
MATT

CLAY

PRODUCT
SPECIFICATIONS

Size : 800x2400mm

Finish : Matt

Body : Full Body

Thickness : 15mm



SCAN FOR
VIRTUAL

360°

Italian Technology |  FLEXIBLE BODY

MONOTONE
SERIES





FLOOR : CLAY | COUNTER TOP : CLAY
BACKSPLASH : CLAY | KITCHEN ISLAND : CLAY



DUST

PRODUCT
SPECIFICATIONS

Size	: 800x2400mm
Finish	: Matt
Body	: Full Body
Thickness	: 15mm



SCAN FOR
VIRTUAL
360°

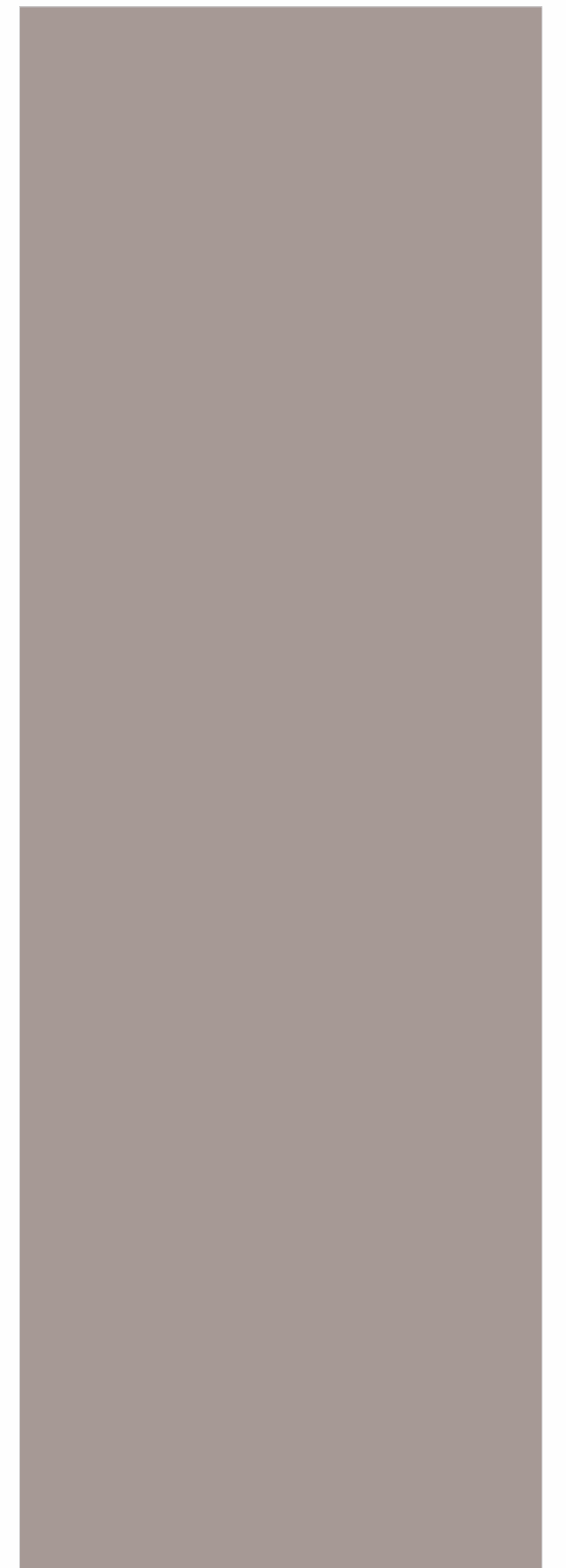



FLOOR : DUST

PASTEL

PRODUCT SPECIFICATIONS

Size	: 800x2400mm
Finish	: Matt
Body	: Full Body
Thickness	: 15mm



SCAN FOR
VIRTUAL
360°





SINK : PASTEL | VANITY TOP : PASTEL



GREVEL

PRODUCT SPECIFICATIONS

Size	: 800x2400mm
Finish	: Matt
Body	: Full Body
Thickness	: 15mm



SCAN FOR
VIRTUAL
360°

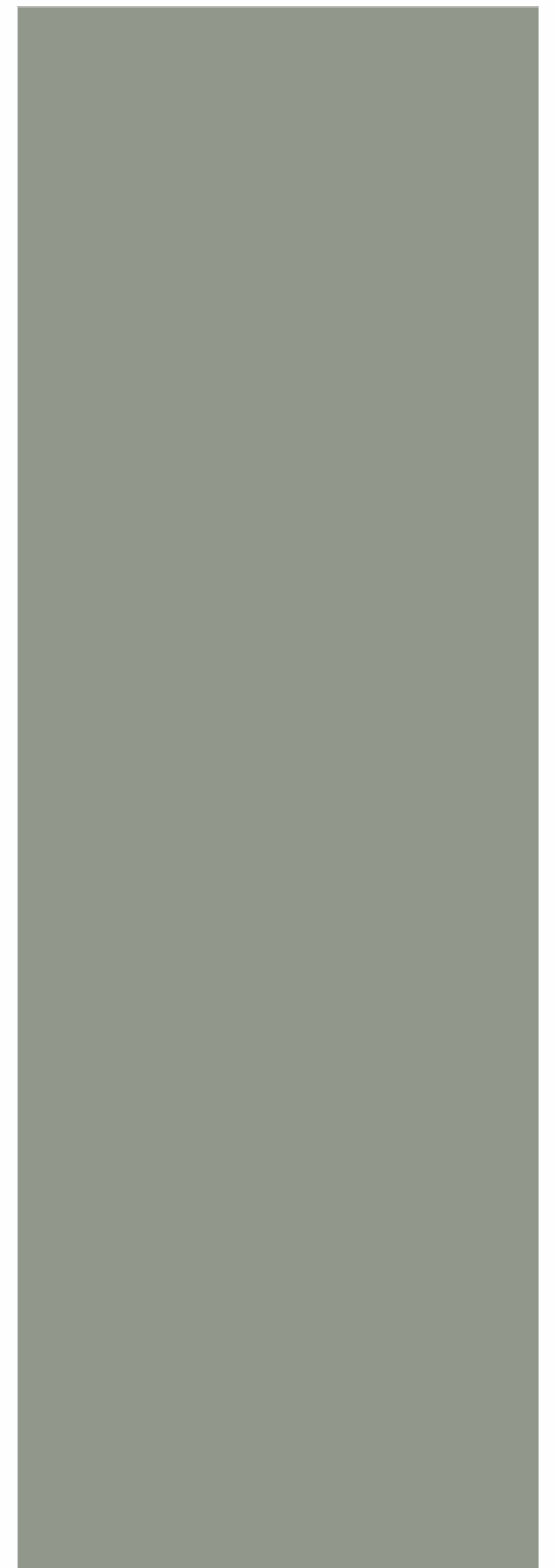



BLEACHER STAIRS : GREVEL

JUNIPER



PRODUCT SPECIFICATIONS

Size	: 800x2400mm
Finish	: Matt
Body	: Full Body
Thickness	: 15mm



SCAN FOR VIRTUAL
360°





STREET FURNITURE : JUNIPER



MIDNIGHT

PRODUCT SPECIFICATIONS

Size	: 800x2400mm
Finish	: Matt
Body	: Full Body
Thickness	: 15mm

PRODUCT COMBINATION



SCAN FOR
VIRTUAL
360°

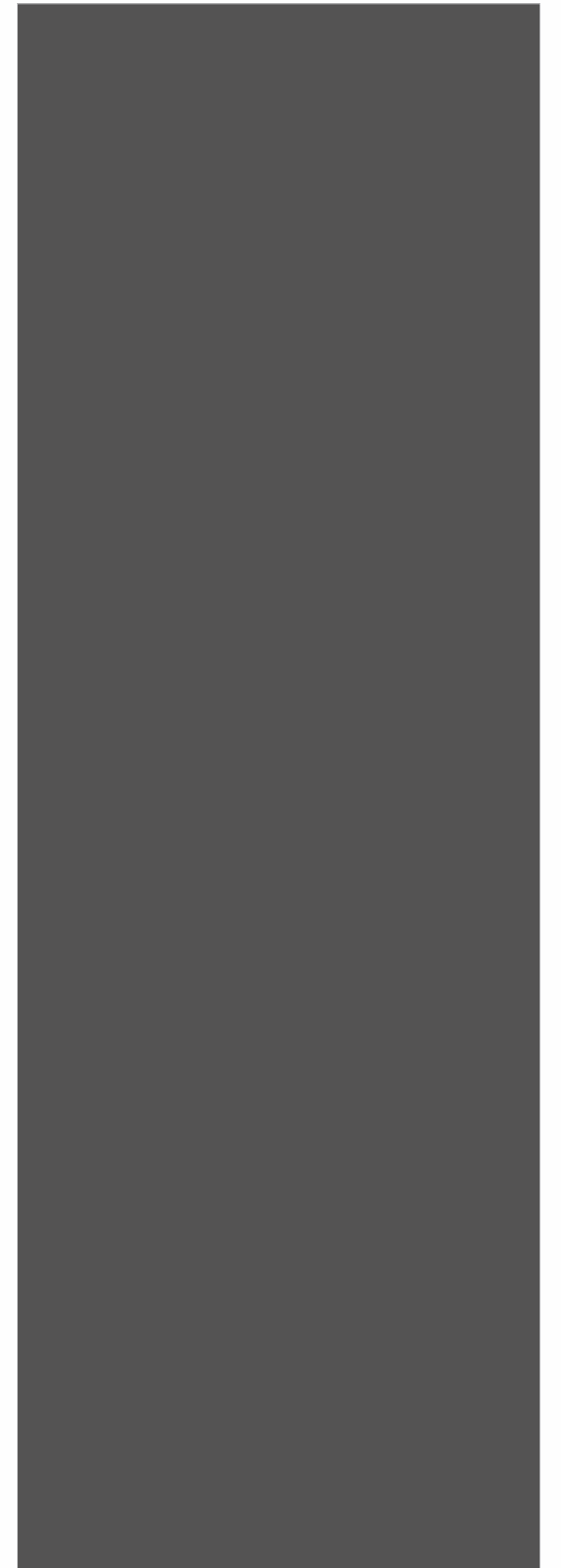



TABLE TOP : MIDNIGHT | FURNITURE CLADDING : PEACH & JUNIPER

OLIVE

PRODUCT
SPECIFICATIONS

Size	: 800x2400mm
Finish	: Matt
Body	: Full Body
Thickness	: 15mm

PRODUCT
COMBINATION



SCAN FOR
VIRTUAL
360°

Italian Technology |  FLEXIBLE BODY

MONOTONE
SERIES





FLOOR : CLAY | SHELF : OLIVE
COUNTER TOP : OLIVE | KITCHEN ISLAND : OLIVE



OXFORD

PRODUCT SPECIFICATIONS

Size	: 800x2400mm
Finish	: Matt
Body	: Full Body
Thickness	: 15mm

PRODUCT COMBINATION

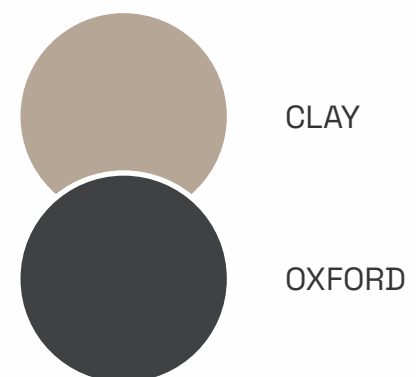

SCAN FOR
VIRTUAL
360°





FLOOR : CLAY | COUNTER TOP : OXFORD
END TABLE : OXFORD

PANTHER

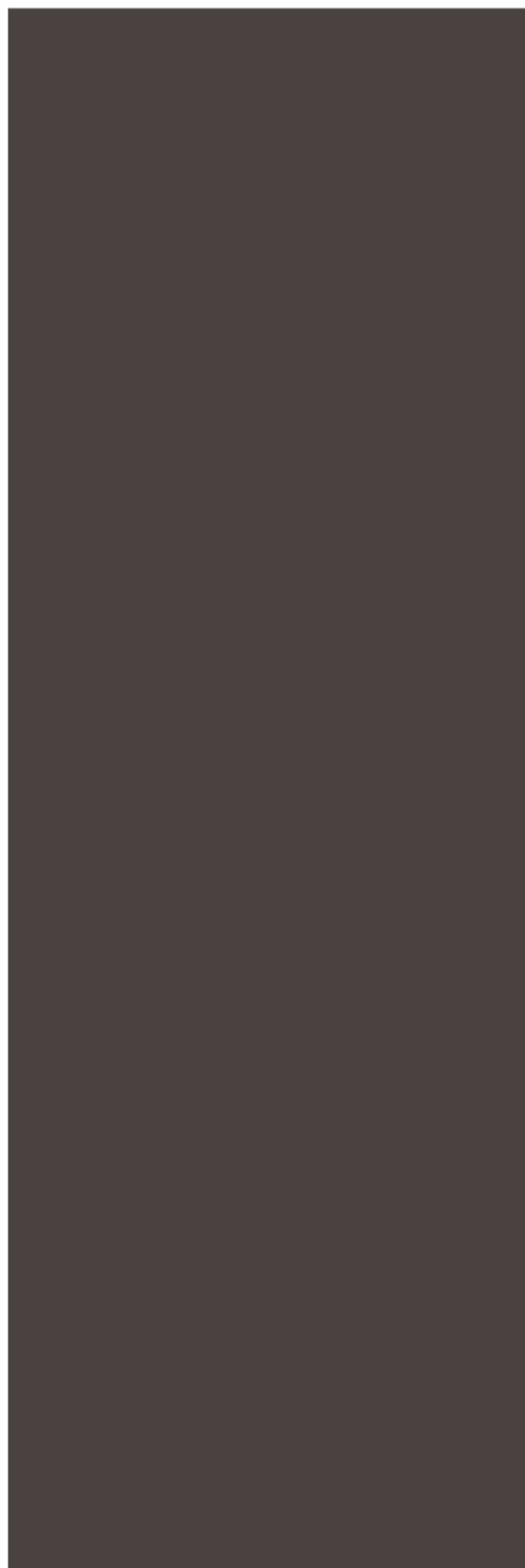

PRODUCT SPECIFICATIONS

Size	: 800x2400mm
Finish	: Matt
Body	: Full Body
Thickness	: 15mm



SCAN FOR
VIRTUAL
360°

Italian Technology |  FLEXIBLE BODY

MONOTONE
SERIES





SERVICE COUNTER : PANTHER



PEACH

PRODUCT SPECIFICATIONS

Size	: 800x2400mm
Finish	: Matt
Body	: Full Body
Thickness	: 15mm

PRODUCT COMBINATION



SCAN FOR
VIRTUAL
360°





WALL : PEACH | FLOOR : CLAY
FIREPLACE : PANTHER | READING TABLE : PEACH

DENIL

PRODUCT
SPECIFICATIONS

Size : 800x2400mm

Finish : Matt

Body : Full Body

Thickness : 15mm



SCAN FOR
VIRTUAL
360°

Italian Technology |  FLEXIBLE BODY

MONOTONE
SERIES





DINING TABLE TOP : DENIL | END TABLE : DENIL

MANUALLY TRANSPORTING SLAB

Only for 1/4" Slabs

MOVING A SLAB

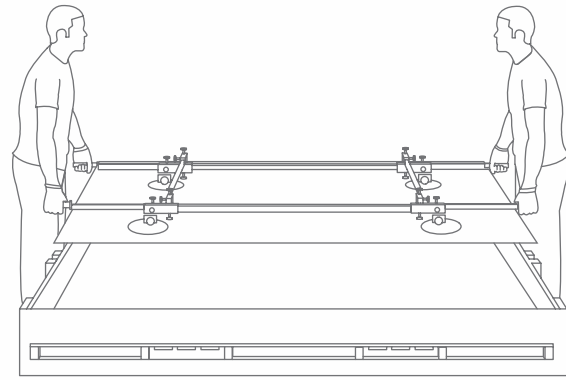
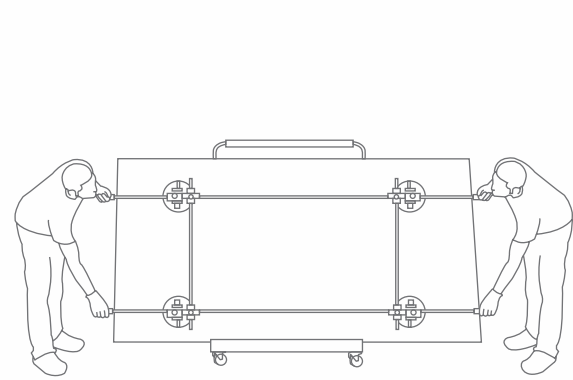

RAISING A IMMODERATE SLAB ONTO A BENCH

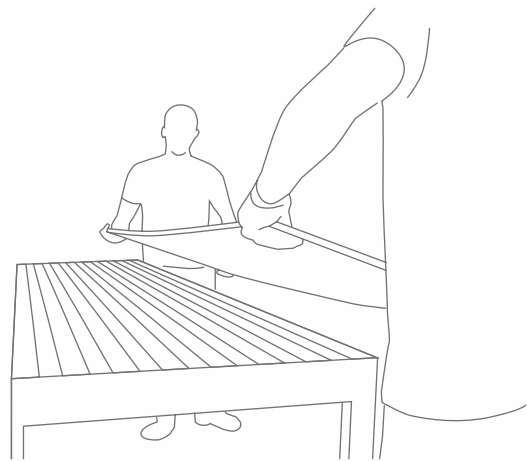

✗ INCORRECT

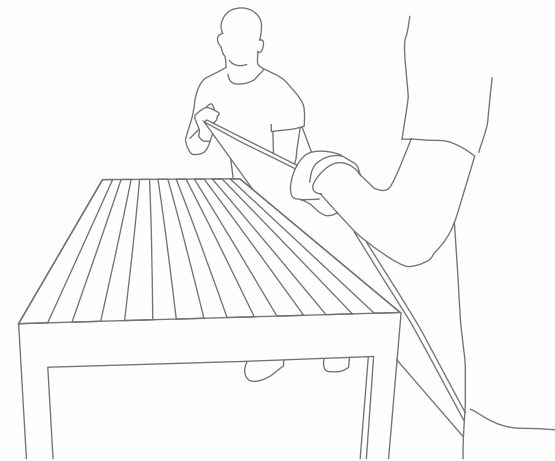

✓ CORRECT

HANDLING IMMODERATE SLAB FOR WALL

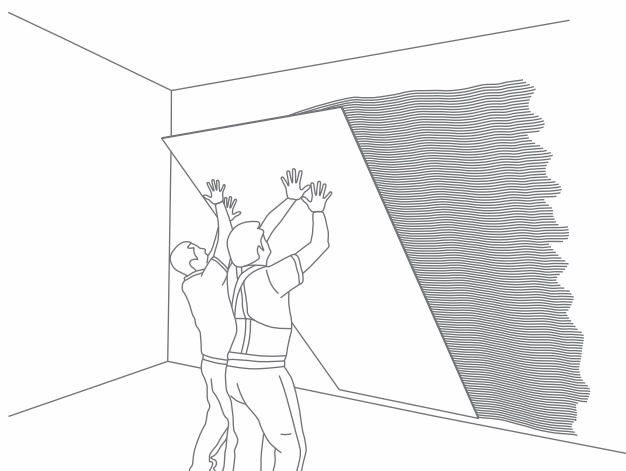

✗ INCORRECT

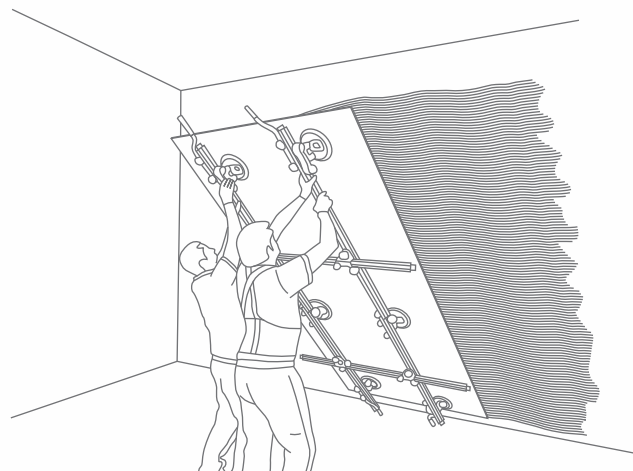

✓ CORRECT

WORKING WITH THE VARIOUS VERSIONS OF SLAB

CUTTING WITH DIAMOND DISCS

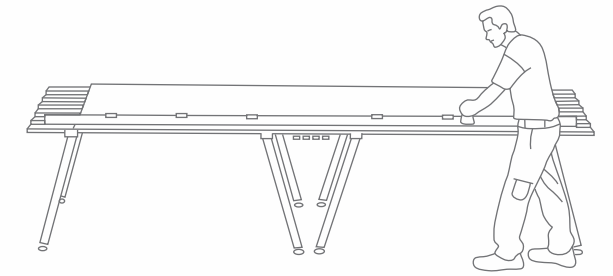
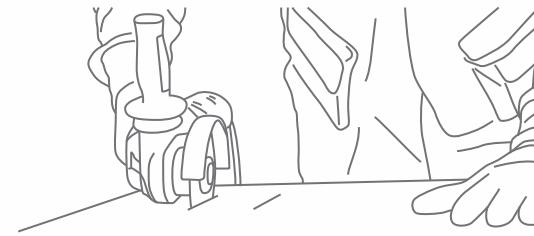

Our products can be cut using diamond discs fitted onto the hand-held electrical grinding machine. The speed of Disc rotation must be high (>10000 RPM) and should have a low feed rate (< 1 m/min). It may be required to cool the disc with water. Recommended discs are the thin types generally used for cutting porcelain stoneware. The surface should be kept on a FLAT base while cutting without any gap underneath.

DRILLING

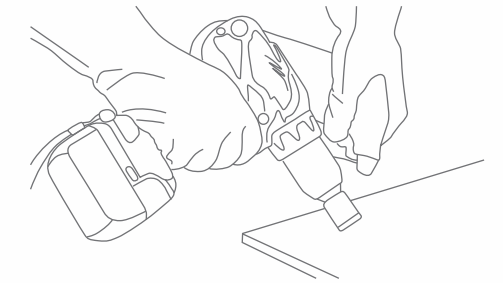
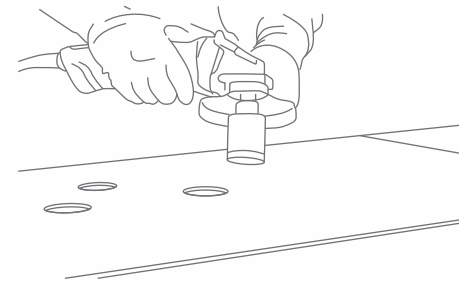

You can use cutting discs fitted to battery-operated screwdrivers or angle grinders, or electrical drills as an alternative.

INTERNAL CUT/L-SHAPED CUT

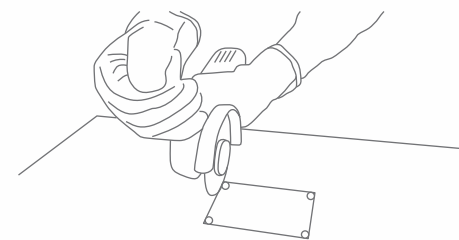

To get internal and L-shaped corners & to reduce the risk of breakage, cut 'o' at the vertex of the internal corners using bits with a radius of at least 5mm. Then cut with diamond discs, be cautious to stop moving the cutting tool forward. To drill and cut using diamond discs, and more follow the instructions provided below:

When using these tools:

- Cool the point being drilled with water
- Don't put too much pressure and bear in mind the resistance of the type of laminated stoneware you are working on
- If you are using tungsten bits, start drilling at a low speed
- If you are using drills or screwdrivers, do not select hammering mode

EDGE-FINISHING

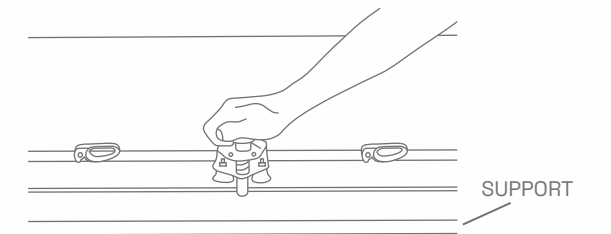
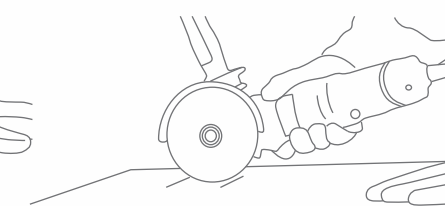

INSTRUCTIONS FOR MANUAL INSTALLATION

SINGLE LAYER METHOD

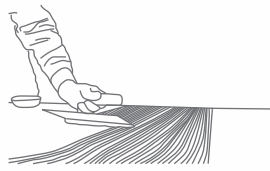

DOUBLE-LAYER METHOD

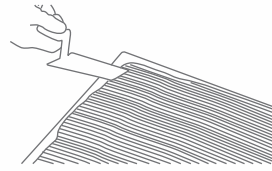

COMPRESSING THE SLAB

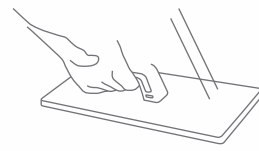

IMPORTANT

All cutout corners must have a minimum diameter of 1/4". Never leave 90° angles. We recommend radius of more than 1/4". when the kitchen design allows as it makes the countertop firmer.



✓ CORRECT



✗ INCORRECT



✗ INCORRECT



✗ INCORRECT

CLEANING & MAINTENANCE

Our products are non porous (due to their high quality raw materials, stringent production parameters and state of the art technology), hence any dust or deposited waste cannot penetrate the surface.

For most cases only a damp cloth is sufficient for cleaning.

Regular cleaning highlights the aesthetic features of the surface and gives it exceptional shine.

For highly aggressive staining caused by some common food and substances follow the table below.

TYPE OF STAIN	CHEMICAL PRODUCT	EXAMPLE
Grease	Alkaline - Solvent	Detergent
Oil	Solvent	Ammonia, Baking Soda
Ink	Oxidant - Solvent	Alcohol, Liquid Bleach, Nail Paint Remover
Rust	Acid	Hydrochloric Acid, Vinegar, Red Harpic
Lime	Acid	Descaling Agents, Hydrochloric Acid
Cement	Acid	Hydrochloric Acid
Wine	Alkaline	Ammonia, Liquid Bleach
Coffee	Alkaline - Solvent	Ammonia, Liquid Bleach
Rubber	Solvent	Alcohol, Thinner
Plaster	Acid	Hydrochloric Acid
Candle Wax	Solvent	Alcohol, Thinner
Iodine	Oxidant	Liquid Bleach
Blood	Oxidant	Liquid Bleach
Ice Cream	Alkaline	Liquid Bleach

Note: It is recommended that any kind of stain needs to be cleaned immediately, as soon as possible.

TECHNICAL SPECIFICATIONS

CHARACTERISTICS	STANDARD AS PER ISO-13006/2018 En14441 gr.bla	MOTTO VALUE	TEST METHOD
Regulatory Properties			
Deviation in Length & Width	± 0.5%	± 0.2%	ISO 10545-2
Deviation in Thickness	± 5%	± 5%	ISO 10545-2
Straightness of Sides	± 0.5%	± 0.2%	ISO 10545-2
Rectangularity	± 0.5%	± 0.2%	ISO 10545-2
Surface Flatness	± 0.5%	± 0.3%	ISO 10545-2
Colour Difference	ΔE<1.00	ΔE<0.30	ISO 10545-16
Glossiness	As per Mfg.	As Per Mfg.	Gloss Meter
Regulatory Properties			
Water Absorption	≤ 0.5 %	≤ 0.3 %	ISO 10545-3
Apparent Density	As Per Mfg.	>2.20 g/cc	ISO 10545-3
Massive Mechanical Properties			
Modulus of Rupture	Min.35N/mm ²	Min.40N/mm ²	ISO 10545-4
Breaking Strength	Min. 1300 N	Min. 5000 N	ISO 10545-4
Impact Resistance	As per Mfg.	Min. 0.55	ISO 10545-4
Surface Mechanical Properties			
Surface Abrasion Resistance	As per Mfg.	Min. class 3	ISO 10545-7
Mohs Hardness	As per Mfg.	Min. class 4	BS EN 15771
Massive Mechanical Properties			
Frost Resistance	As Per Mfg.	Frost Proof	ISO 10545-12
Thermal Shock Resistance	Min. 10 Cycle	Min. 10 Cycle	ISO 10545-9
Moisture Expansion	Max. 0.6mm/m	Max. 0.02mm/m	ISO 10545-10
Thermal Expansion	Max. 9.0 x 10 ⁻⁶	Max. 6.0x10 ⁻⁶	ISO 10545-8
Chemical Properties			
Chemical Resistance	As Per Mfg.	No Damage	ISO 10545-13
Stain Resistance	Resistant	Resistant	ISO 10545-14
Safety Properties			
Slip Resistance	As per Mfg.	N. A.	DIN 51130
Fire Resistance	As per Mfg.	Fire Proof	N. A.

PACKING DETAILS

Dimension (mm)	No. of Pcs/Box	Square Feet	Weight (Approx)
800x2400mm	1 Pcs.	20.67 Sq. ft	68 kg.



MOTTO GROUP

8-A, National Highway, Sartanpar Road, At. Sartanpar,
Ta. Wankaner, Morbi - 363 621, Gujarat, INDIA

Mail. info@mottogroup.in, **Web.** www.mottogroup.in

Toll-free. 1800 123 2124

Call. +91 95123 80072

Scan for Catalogue

